

# Christian Bollin Armaturenfabrik GmbH

Westerbachstraße 290-294, 65936 Frankfurt, Tel.: 069/341021; Fax: 069/343985

e-mail: [bollin@bollin.de](mailto:bollin@bollin.de), Internet: [www.bollin.de](http://www.bollin.de)

## INSTALLATION / SERVICE / ASSEMBLY INSTRUCTIONS

### for valves and manifolds with outside spindle thread

BOLLIN-globe valves are maintenance-free as far as possible and allow a simple operation.

- All BOLLIN valves have a positive metal-to-metal seal and a manual actuation; whereby closing will be effected by rotating clockwise and opening by rotating anticlockwise.

#### Starting:

- Rust, sand and similar impurities into the product - or by the first rinse before starting can cause leakages if they collect in the seat area. The spindle is therefore fully to open to allow a proper rinsing.
- For storage reasons, the rough-pressed packing can set and its closeness can decrease. By starting, this packing is to adapt.

#### Adaptation:

- If a valve is going to be leaky in the packing, the ring nut (part 8) is to screw down slightly with the help of an open-end adjustable wrench clockwise and the spindle (part 3) is to move 2-3 times. In most cases, the packing does immediately seal again.

#### Change of packing:

- If the adaptation of the packing is not showing a good result, you will have to change the packing.

#### Procedure:

1. Turn line system to be unpressurized, open valve.
2. Screw off cap nut (part 10); take off handwheel (part 9).
3. Screw out complete head piece (part 4).
4. Unscrew spindle (part 3) to the bottom.
5. Turn ring nut (part 8) to the top, remove stuffing box (part 7) at the side.

6. Push out packing (part 6) from the bottom.
7. Clean packing area and use new greasy packing.
8. Put in stuffing box (part 7).
9. Inset spindle (greased in the screw thread region) from the bottom and screw it completely to the top.
10. Screw down ring nut (part 8) slightly.
11. Change sealing ring (part 13) in any case and grease it gently.
12. Grease thread of the top and screw it in. Screw down with 170 Nm.
13. Put on handwheel (part 9); screw on cap nut (part 10).

#### Exchange of spindle and/or seat:

- seat and cone (rolled up in spindle) are exchangeable.

#### Procedure:

1. Same procedure as "change of packing", points 1. - 3.
2. Unscrew seat (part 2) with the help of a spanner.
3. Screw in and down new seat (greasy in screw thread region).
4. If necessary, exchange cone with spindle (part 3) (see "change of packing", point 4.). Re-mounting of the spindle (see "change of packing", points 9. and 10.).
5. Re-mounting of the head piece (see "change of packing", points 11. - 13.).

#### Annotation:

For valves free of oil and grease use admitted lubricant and package.

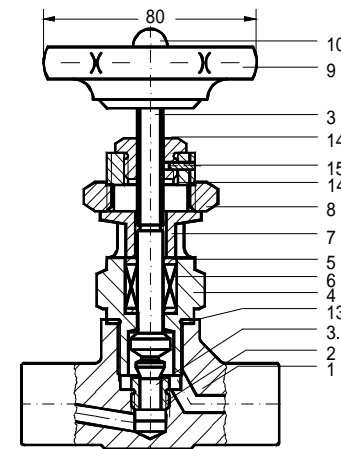

Wartungsanl-englisch-außenl.-Spindelgew.-wie A7A-A11A-A17A